

# Single Plug Installation Instructions - 1981-on Airheads

OMEGA Electronic Ignition Type V /7/RS/RT/CS - S/N 2001xxxxx and up

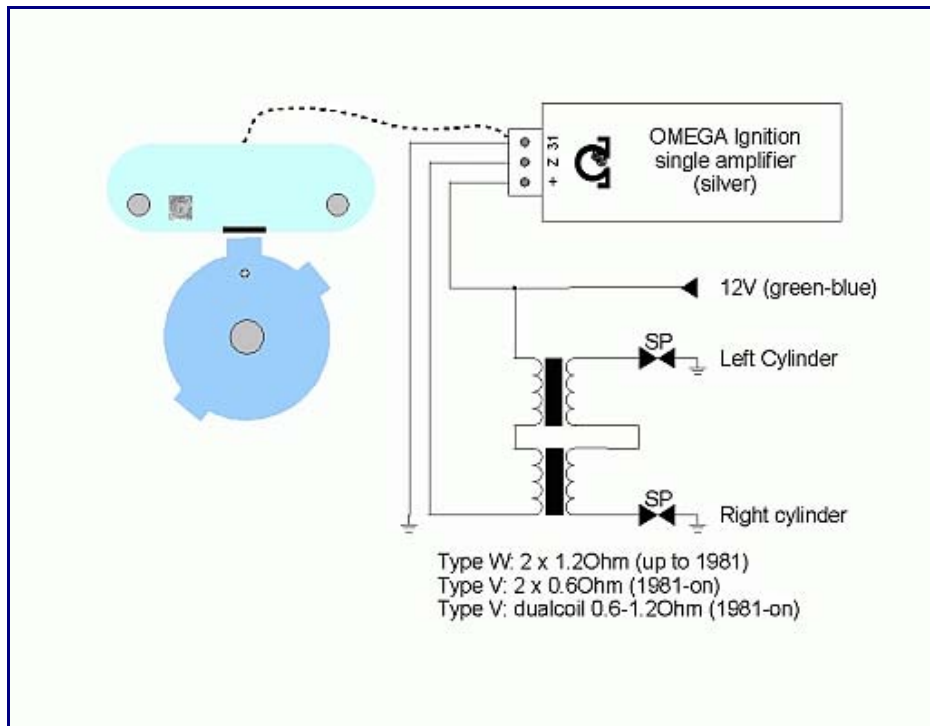

## Ignition Characteristics Type:

- Electronic Ignition Type V for 1981-1995 BMW 2-cyl motorcycles a.k.a. Airheads with temperature-compensated micro-processor
- No. of selectable advance curves: 15 + zero advance
- 25° to 47° max. advance depending on chosen advance curve
- Required coil resistance: (stock coils/dualcoil) 0.5 to 5.0 Ohm, 4.5mH max.

## Bill of Material for Type V Electronic Ignition

- 1 x Magnet Carrier with embedded magnet and special tool (Allen key)
- 1 x Printed Circuit Board with connector
- 1 x Ignition Amplifier (silver)
- 1 x Special ISK alternator bolt and spacer
- screws and wave washers
- two (2) brass SK-pieces
- two (2) plastic screw
- wire, connectors and insulating tube to fabricate required interconnecting cables ([click for picture if online](#))
- this detailed installation instruction



**CAUTION: Sensitive electronic parts.**

**Do not pull spark plug wires from plugs to perform carburetor balancing without proper grounding.**

## Installation and adjustment of the OMEGA Type V Electronic Ignition

1. Disconnect battery (always work with the battery disconnected)
2. Remove engine cover
3. Remove alternator bolt (block the crankshaft by applying the rear brake, use a helper if needed)



4. Fit the (silver) booster with the supplied M4x30 screw to the M4 thread above the alternator stator.



5. Remove ALL washers and install the two brass spacers onto the two studs with the recess facing up, replacing the stock nuts.

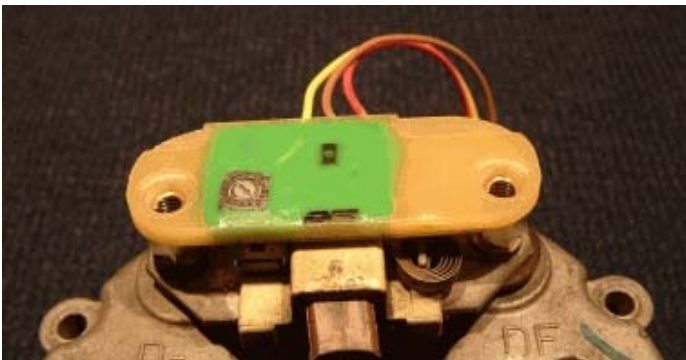

6. Place the printed circuit board onto the two brass spacers (slotted holes fitting the recess, chip facing downwards) and move it to the furthest away position so that the rotating magnet carrier does not interfere with the board (widest gap). Adjust final gap in Step 9.

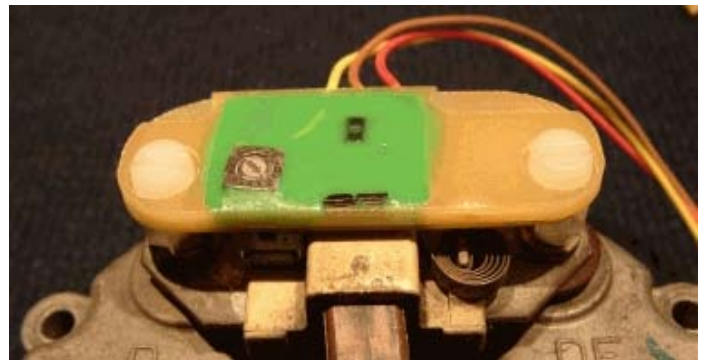

7. Affix the printed circuit board via the two plastic screws provided (do not use metal screws - risk of electrical short), shorten plastic screws with x-acto blade if necessary, use of red Loctite recommended. Install the plastic sleeve to protect the cable and connect the printed circuit board connector to the (silver) amplifier.



8. Use the Special ISK alternator bolt with the aluminum spacer (do not use the stock washer) in lieu of the original alternator bolt.

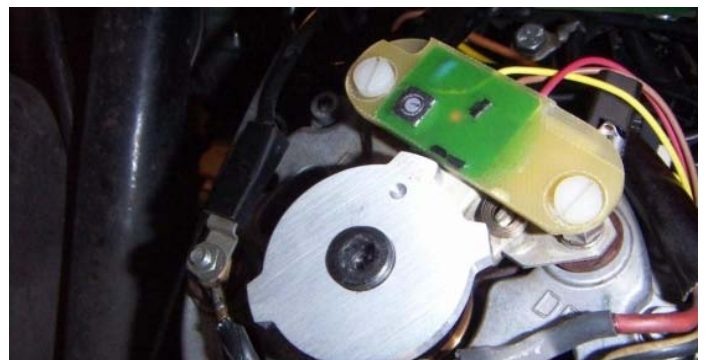

9. Slip the magnet carrier (balance hole outwards) over the alternator bolt head and carefully tighten setscrew with the supplied Allen key. Rotate the magnet carrier so either bump is at the sensor and set gap to .5mm (0.02"). The gap should be as close as possible but not touching, the magnet carrier should never contact the board.

Electrical Connections (using the wiring material provided) :

- 10. Connect Terminal 31 of silver OMEGA Ignition to any suitable chassis grounding point using the brown cable with the ring terminal attached (as provided in the installation kit), e.g. the M5 thread in the timing cover just underneath the diodeboard
- 11. Connect Terminal + of amplifier to Terminal 15 of coil (you may route the wire directly through the timing cover grommet) using the long green/black cable (as provided in the installation kit, color may vary)
- 12. Connect Terminal Z of amplifier to Terminal 1 of coil (you may route the wire directly through the timing cover grommet) using the long black cable (as provided in the installation kit, color may vary)

Note on 1991-1995 Airheads (some models): for the Engine Stop switch to remain functional, the OMEGA ignition amplifier Terminal + has to be connected to the main wiring harness: disconnect the stock ignition module from the main wiring harness by separating the mated 3 pin connectors. Use the green/yellow wire in the 3 pin female housing to connect to the "+" terminal of the ignition amplifier.

## OMEGA wiring for Airheads ... 1981-1995

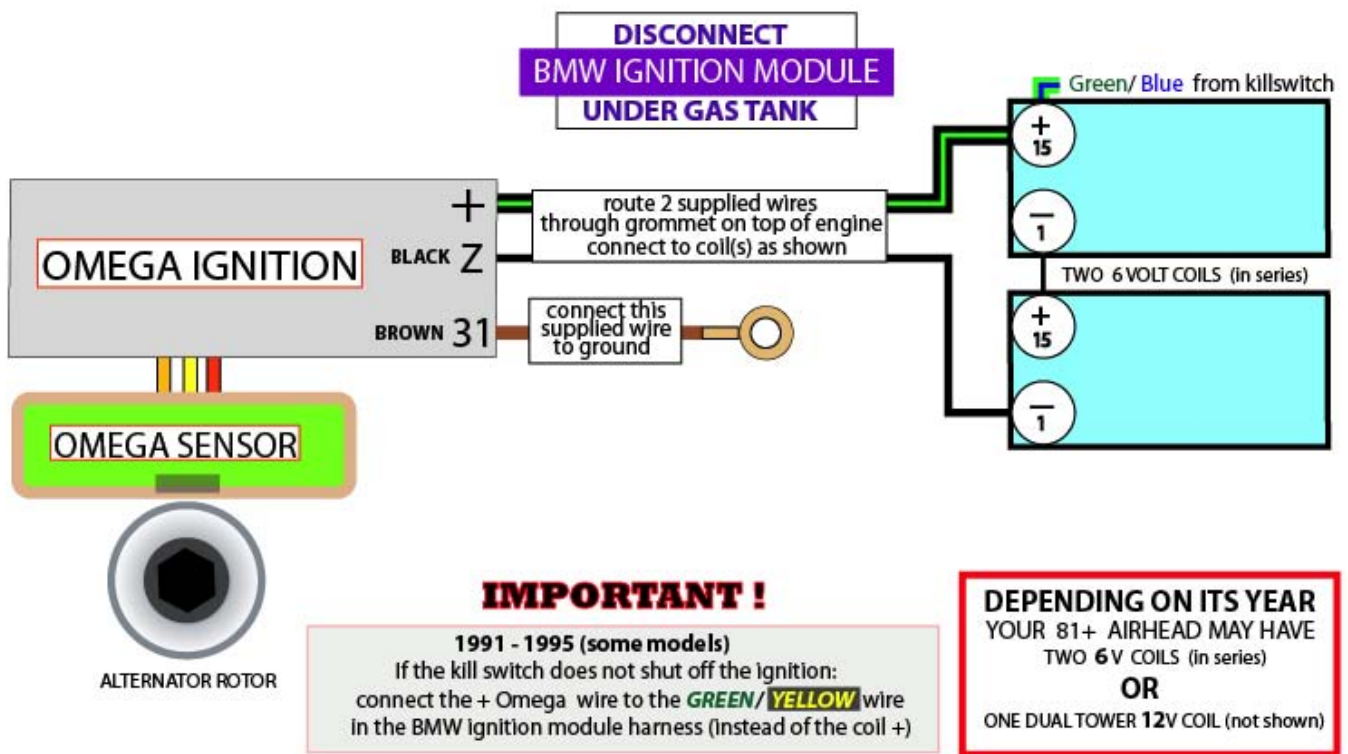

**NOTE: LEAVE ALL YOUR OTHER IGNITION WIRING AS IS, DO NOT DISCONNECT ANY WIRES**

*(graphics courtesy gspd, Montreal)*

Adjusting ignition timing:

13. Connect battery, remove caps from the spark plugs to prevent the engine from firing accidentally when turned over in Step 14, turn ignition ON
14. Turn the engine clockwise (using the alternator rotor bolt or the kickstarter or the rear wheel with the gearbox in 5<sup>th</sup> gear) until the "S" mark aligns with the timing hole mark, then turn the magnet carrier clockwise until the integrated LED light just comes on
15. Hold the magnet carrier in this position and tighten the setscrew carefully with the provided Allan key
16. Turn ignition OFF, reconnect the spark plugs, turn ignition ON and start the engine
17. You may set the ignition advance curve to position "0" ( 0° advance for test purposes, see further below) to prevent the ignition from advancing at all, for the purpose of this test: check (using a timing light) that the „S“ mark is in fact centered in the timing hole while the engine idles. If it is not, re-position the magnet carrier slightly either way by repeating step 14-16.
18. Choose the appropriate advance curve by carefully adjusting the microswitch located at the left hand side of the printed circuit board: advance curve "4" is default setting for /6/7 and later models
19. Check both, idle setting and advance timing with a timing light; if advanced timing is incorrect (F-mark not in center of window at approx 3000-3200rpm), choose the next higher or lower advance setting, the following advance curves are pre-programmed into the unit:

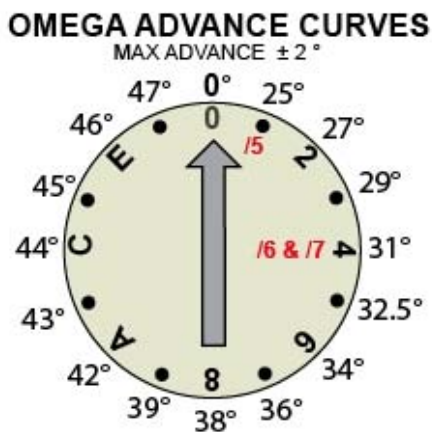

*(graphics courtesy gspd, Montreal)*



**CAUTION: Sensitive electronic parts.**

**Do not pull spark plug wires from plugs to perform carburetor balancing without proper grounding.**

**Application Note:**

Use of stock spark plugs is recommended. It is required for the alternator to have adequate air cooling (user comment: installation in a stock R75/5 which has a solid engine cover, did not create any damage even after daylong rides in the hottest season). Damage as a result of a short circuit and wrong connection during installation is not covered by the warranty.